



**SUESSCO**  
SENSORS

# Operating Manual

## 3D- & 6D-Sensor



Dear customer!

You have chosen a high-quality product with innovative and patented magnetic field technology from SuessCo Sensors. We strive for highest precision paired with efficient installation and carefree operation. We thank you for your trust and hope that the sensor meets your expectations. If you have any questions or suggestions, please do not hesitate to contact us.

Yours sincerely,









Ernst Windhör, CEO









---

## Content

1. Safety instructions .....	3
2. General provisions.....	5
3. Scope of delivery .....	6
4. Positioning the sensor.....	7
4. Installation 3D-Sensor .....	9
5. Installation 6D-Sensor .....	10
6. Activate 3D- and 6D-Sensor .....	11
7. SuessCo Datahub .....	12

## 1. Safety instructions

<b>DANGER</b>	
	<b>Risk of injury from electrical components!</b> Pay attention to electrical hazards in the area of electrical components. Only authorised and trained personnel are permitted to work on electrical components.
<b>DANGER</b>	
	<b>Risk of injury on the battery box!</b> Be aware of the dangers of incorrect handling or unauthorised access to the battery box. Only authorised and trained personnel are permitted to work on the battery box.
<b>WARNING</b>	
	<b>Risk of injury due to falling!</b> If the sensor falls to the ground, it must be checked for damage immediately. If the sensor is damaged, it must not be put into operation.
<b>WARNING</b>	
	<b>Risk of injury due to incorrect installation!</b> Ensure that the sensor is always installed correctly. Check the installation regularly.
<b>WARNUNG</b>	
	<b>Risk of injury from unqualified persons!</b> It is strictly forbidden to open the housing of the sensor. It may only be removed by authorised personnel.
<b>WARNING</b>	
	<b>Risk of injury due to incorrect use!</b> The device must never come into contact with water.
<b>WARNING</b>	
	<b>Risk of injury for children!</b> Ensure that children never use the appliance unsupervised. The appliance is not a toy.

<b>WARNING</b>	
	<b>Risk of injury due to environmental influences!</b>
	It is strictly forbidden to store the sensor outdoors. Always protect it from environmental influences.
<b>WARNING</b>	
	<b>Fire hazard due to dirt deposits!</b>
	Regularly remove dust and dirt deposits from all cable connections and cables.
<b>WARNING</b>	
	<b>Risk of injury due to incorrect cleaning!</b>
	Ensure that the sensor is always cleaned properly. Always follow the instructions in the operating instructions.
<b>WARNING</b>	
	<b>Risk of injury due to damage!</b>
	Check the connections regularly for damage or similar anomalies.
<b>WARNING</b>	
	<b>Risk of injury due to incorrect spare parts!</b>
	Only ever use original spare parts recommended by the manufacturer.
<b>WARNING</b>	
	<b>Risk of injury due to incorrect storage and use!</b>
	The battery box may only be operated and stored with the lid closed.
<b>CAUTION</b>	
	<b>Risk of crushing!</b>
	Be aware of the risk of crushing between the magnet and sensor.
<b>CAUTION</b>	
	<b>Risk of injury due to damage!</b>
	Make sure that you avoid damaging the magnet. If the magnet is damaged, you must replace it.

## 2. General provisions

In general, the following safety regulations and obligations apply when handling the sensor:

- The sensor may only be operated if it is in perfect and clean condition.
- It is prohibited to remove, modify, bypass or circumvent any protective, safety or monitoring device.
- It is forbidden to modify or alter the sensor.
- Faults or damage must be reported to the operator immediately. These must be rectified immediately using original parts.
- For any activity other than the intended use in the area of the sensor, it must be depressurised and de-energised and secured against being switched on again.
- Only original spare parts may be used for repairs.
- The safety and operating instructions in the documentation for the components used must always be observed.
- All protective, safety and monitoring equipment must be regularly checked and maintained by the operator (see maintenance schedule).
- Only instructed, trained or qualified persons may carry out work in the area of the sensor.
- The maintenance work must be carried out and documented in accordance with the maintenance plan provided.
- After maintenance or repair, the sensor may only be started up with all protective devices fitted. A responsible person must be appointed to check that the protective devices are properly fitted.
- The national employee protection regulations and the national safety and accident prevention regulations apply to the operation of the sensor.

### 3. Scope of delivery

The following elements are included in the scope of delivery. Additional mounting material is required for installation.

The 3D-Sensor has internal batteries and an integrated antenna. The 6D-Sensor has an external power supply, which can be obtained from your dealer.



a) Sensor



b) Reference object



c) Activation magnet



d) Mounting plate



e) Screws



f) Antenna (6D-Sensor)

*1 Scope of delivery*

#### 4. Positioning the sensor

The reference object b) should be positioned in the centre of the measuring range of the sensor a). Markings on the sensor tongue and the reference object indicate the centre point.

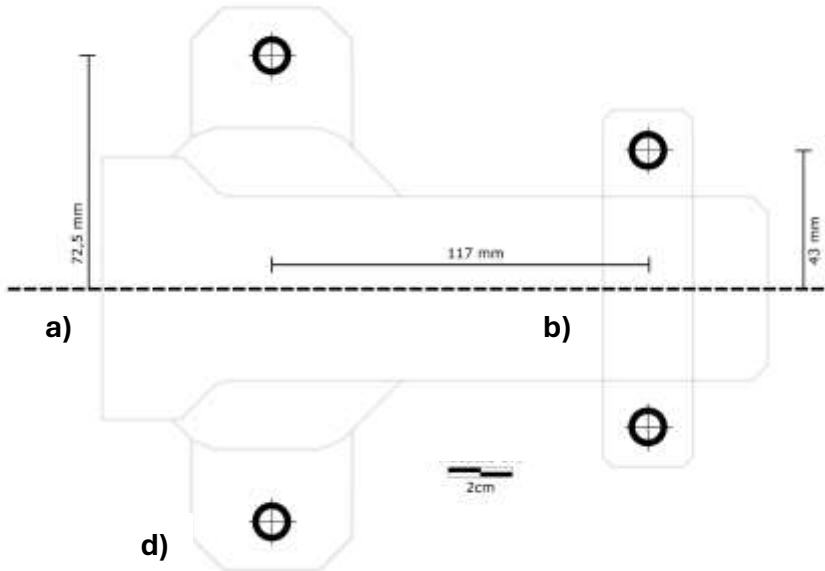

2 Example for drilling template

**Attention:** Graphic is not true to scale.

You can find a printable template at [www.suessco.com/support/](http://www.suessco.com/support/)

## 5. Preparation of 3D- and 6D-Sensor

The sensor a) must be screwed to the mounting plate d) before installation. Use the supplied screws and washers e).

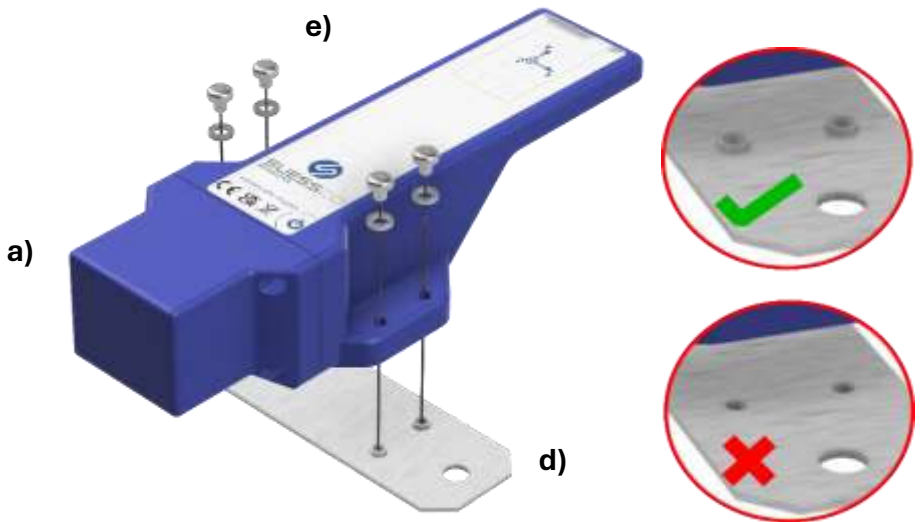

### 3 Installation of mounting plate

1. Ensure that the mounting plate is correctly aligned. The four bulges point in the direction of the sensor base.
2. Position the sensor on the mounting plate so that the bulges of the mounting plate engage in the holes of the sensor.
3. Position a screw with a washer over each hole. Tighten the screws crosswise using a 3 mm allen key. The recommended tightening torque is 1 Nm to 1.5 Nm.



## 6. Installation 3D-Sensor

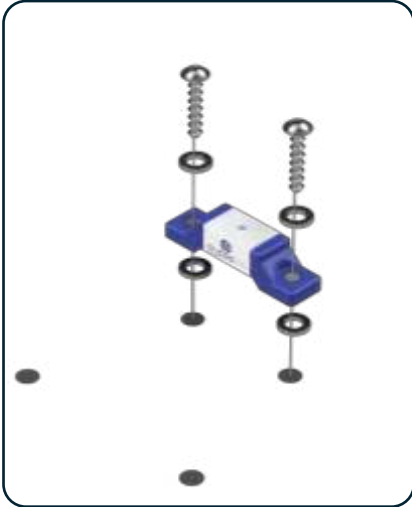

4 1.) Install reference object

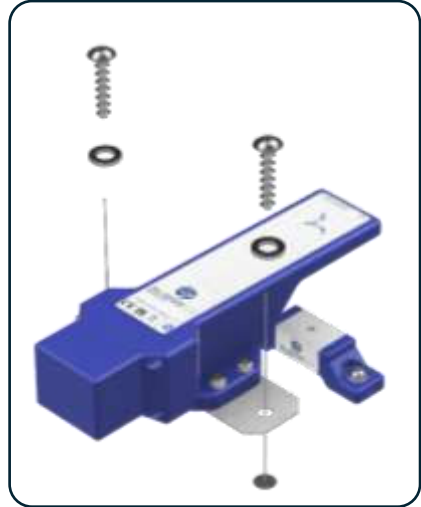

5 2.) Install sensor

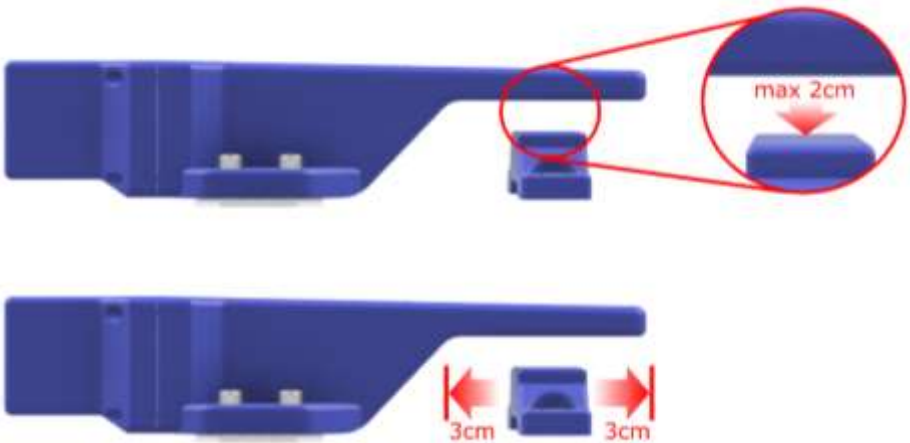

6 Regard the measuring range

The 3D-Sensor has internal batteries and an integrated antenna. The sensor can now be activated - see chapter "SuessCo Datahub"

## 7. Installation 6D-Sensor

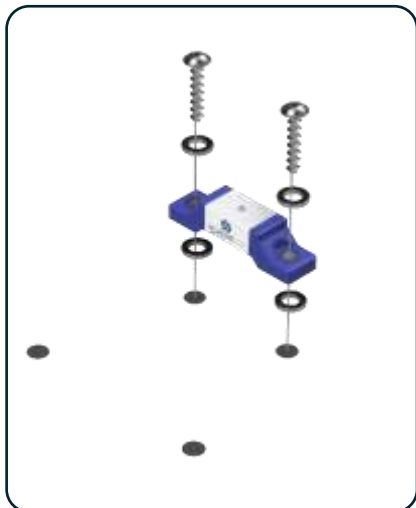

7 1.) Install reference object

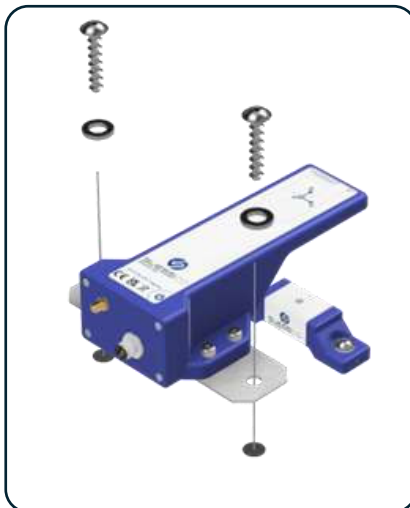

8 2.) Install 6D-Sensor

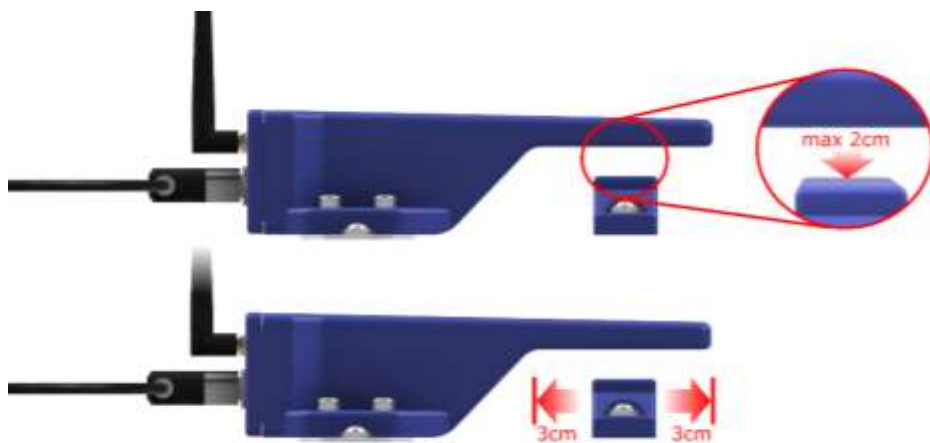

9 Regard the measuring range

## 7.1. Connections 6D-Sensor



10 Connectors of the 6D-Sensor

### **Antenna:**

Connect the antenna f) to the antenna connection.

### **Power cable:**

Connect the sensor and the battery or power supply box using the cable provided.

## 8. Activate 3D-Sensor

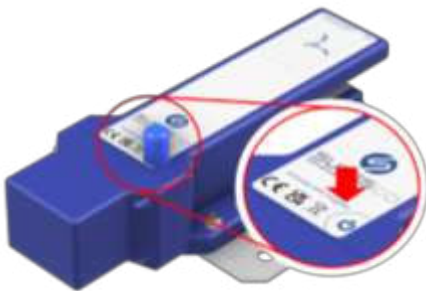

11 Activation magnet on 3D-Sensor

1. Place the activation magnet on the marked area of the sensor for 3 seconds.
2. Wait for the confirmation tone. Remove the activation magnet.
3. Your sensor is ready for use. You can monitor the operating status of your sensor and all measured values in the SuessCo Datahub.

If the activation was not successful, remove the magnet for at least 30 seconds. Start again with step 1.

### **Activate 6D-Sensor:**

The 6D-Sensor will activate itself, when connected to a power supply.

## 9. SuessCo Datahub

The SuessCo Datahub is the central web platform where all the sensor's measured values and functions are collected and displayed.

The address is **datahub.suessco.com**

You will receive your personal access details from the dealer from whom you purchased the sensor. If you have not yet received your access details, please contact your dealer directly.

---

For further information  
please visit our homepage

[www.suessco.com](http://www.suessco.com)

### **Imprint:**

SuessCo Sensors GmbH  
Wiener Strasse 6  
3130 Herzogenburg  
Austria



**SUESSCO**  
SENSORS